

# bj·gear

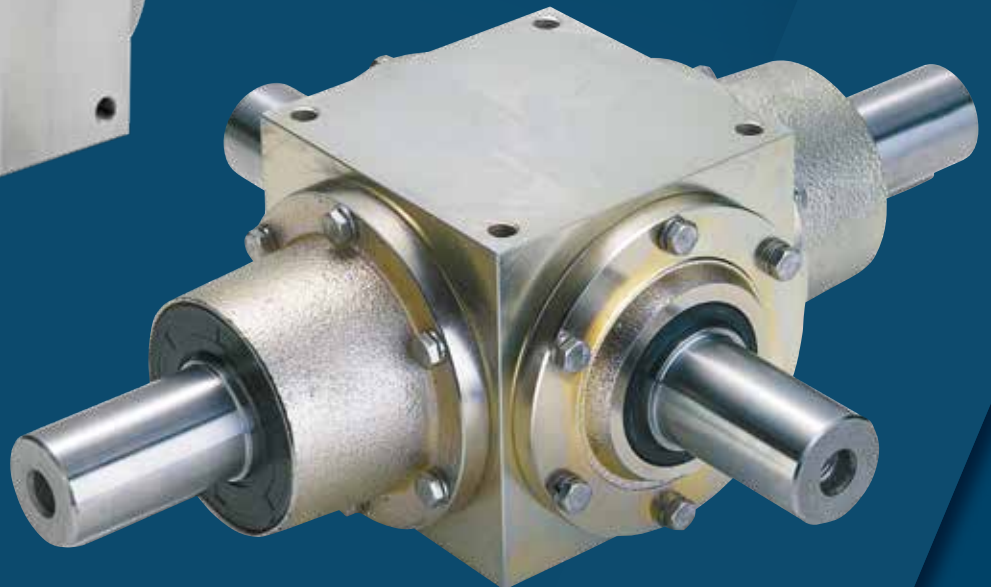

## STRONG

Spiral bevel gearboxes for continuous operation

Customisation is our standard

## Customisation is our standard

**BJ-Gear A/S is known for reliable transmission solutions and our ability to customise our products to fit your exact needs.**

We produce a wide range of standard gearboxes and actuators, and supply e.g. motors, encoders, electromagnetic brakes and couplings of recognised manufacturers, making it possible to supply complete transmission solutions at short notice.

The flexible production machinery together with our modular designed product range allows very short and precise delivery times.

The combination of innovation, know-how, high-technology production facilities and our focus on customer requirements makes us a competent partner.

BJ-Gear is known for reliable transmission solutions for industries such as healthcare, food processing and packaging, aerospace and defense, offshore and marine, the energy and environment sector as well as many other business areas.

## STRONG by BJ-GEAR for continuous operation

BJ-Gear's STRONG gearboxes are BJ-Gear's line of spiral bevel gearboxes. The STRONG gearboxes can be used for continuous operation on all types of industrial machinery. The compact construction and design allows mounting in any position, even at limited space. The angle gearboxes have a quiet running and are constructed with a long operating life in view.

The gearboxes are made in cast iron GG25 or stainless steel and are prepared for direct fixing at machinery fundamentals. The gear wheels are made of high quality alloy steel and hardened. STRONG gearboxes can be delivered as standard with ratio 1:1 and 2:1

The STRONG spiral bevel gearboxes can be delivered with 2 or 4 shafts, in ratio 2:1 up to 6 shafts, and can be mounted horizontal or vertical as desired. They can be fitted with flange motor and with flange for fixing at machinery frames. All gearboxes are supplied lubricated for life time. The gearboxes can be delivered with speed increasing 1:2.

STRONG bevel gearboxes are manufactured in four different types. Common to these are that pinion and wheel are made with Klingelnberg Pallowid spiral toothing:

Type K is the standard version with bearing support that consists of powerful ball bearings on polished bearing seats.

Type P and V are gearboxes designed for transmission of high torque at low rpm, while the bearing support consists of strong conical tapered roller bearings. The two types have dimensional differences.

Type L is a special gearbox produced according to customer requests. Often, the pinion and wheel are patched in pairs.

See examples of gearbox solutions page 7.

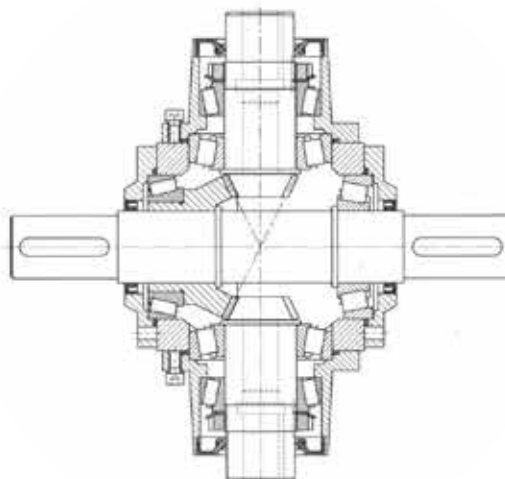











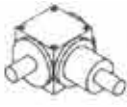
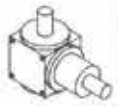



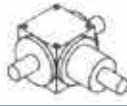

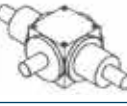

## Type K - efficiency data

Permissible power $P_1$ [kW] and rated output torque $M_2$ [Nm]													
Ratio	Input rpm	Gear sizes											
		20		25		30		35		40		50	
		$P_1$ kW	$M_2$ Nm	$P_1$ kW	$M_2$ Nm	$P_1$ kW	$M_2$ Nm	$P_1$ kW	$M_2$ Nm	$P_1$ kW	$M_2$ Nm	$P_1$ kW	$M_2$ Nm
1:1	10	0,083	75	0,12	110	0,22	200	0,42	380	0,77	700	1,1	1000
	100	0,8	72	1,2	108	2,2	200	4,1	375	7,4	670	10,8	980
	250	1,9	69	2,8	104	5,4	195	10,0	362	16,5	600	25,6	930
	500	3,4	62	5,5	100	9,9	180	17,0	308	30,3	550	46,3	840
	750	4,8	58	7,5	91	14,0	170	24,0	290	43,0	520	64,5	780
	1000	5,7	52	9,1	83	18,2	165	30,2	274	52,3	475	80,5	730
	1500	7,8	47	12,4	75	24,8	150	41,0	248	69,4	420	111	675
	2000	8,8	40	15,4	70	30,8	140	46,7	212				
	3000	10,5	32	21,5	65								
2:1	10	0,04	76	0,06	114	0,11	210	0,21	380	0,38	700	0,58	1050
	100	0,4	72	0,6	110	1,1	206	2,1	376	3,75	680	5,5	990
	250	0,96	70	1,4	104	2,7	196	5,0	365	8,5	620	13,0	940
	500	1,8	68	2,8	100	5,0	184	8,5	310	15,4	560	23,3	845
	750	2,7	66	3,8	92	7,0	170	12,2	295	22,0	530	32,2	780
	1000	3,5	64	4,8	88	9,0	164	15,2	275	26,4	480	40,5	735
	1500	5,1	62	6,7	82	12,4	150	20,6	250	35,1	425	56,2	680
	2000	6,3	57	8,5	77	15,4	140	25,6	233				
	3000	8,9	54	12	73								

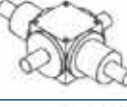
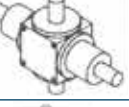
■ Please contact our Sales Department for further information.  
Efficiency data for type P and V can be found on page 12.

## Type K, V and P

Mounting positions

Pos.nr. Type	1	2	3	4	5
CB					
C2B					
B2C					
2B2C					
3C					

## Type K - service factors

Type K	Service factors								
	Starts per hour								
	≤ 10			11-150			>150		
Working conditions	Intermittent operation up to 3 hours a day	Normal operation 8-10 hours a day	24 hours operation a day	Intermittent operation up to 3 hours a day	Normal operation 8-10 hours a day	24 hours operation a day	Intermittent operation up to 3 hours a day	Normal operation 8-10 hours a day	24 hours operation a day
1. Smooth, shock free loading and low starting torque	0,8	1,0	1,25	1,0	1,25	1,5	1,25	1,5	1,75
2. Moderate shock loads and medium starting torque	1,0	1,25	1,5	1,25	1,5	1,75	1,5	1,75	2,0
3. Smooth loading with periodically heavy shock loads and high starting torque	1,25	1,5	1,75	1,5	1,75	2,0	1,75	2,0	2,25
4. Heavy continuous shock loads and very high starting torque	1,5	1,75	2,0	1,75	2,0	2,25	2,0	2,25	2,5

At > 1000 < rpm input					
Gear size	Torque Nm	Radial load Pr max N	Axial load Pa max N	Weight Kg	Oil L
K-20	75	1000	900	9	0,5
K-25	110	1400	1250	15	0,75
K-30	200	2000	1750	22	1,0
K-35	380	2500	2000	38	2,0
K-40	700	3500	2750	55	3,0
K-50	1000	4500	3500	80	6,0

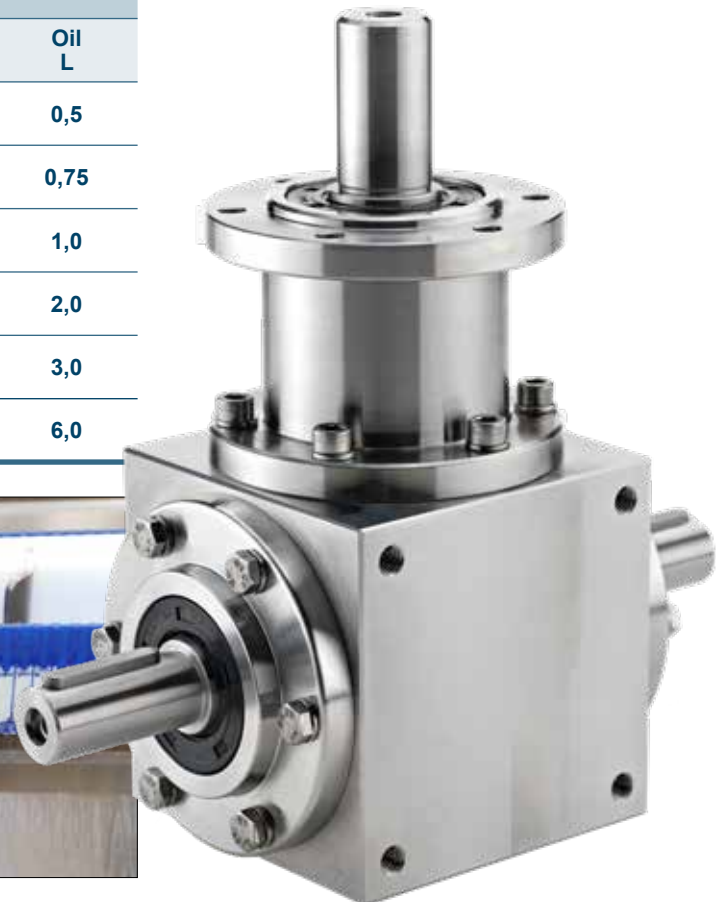

# Type K - list of models

i = 1:1

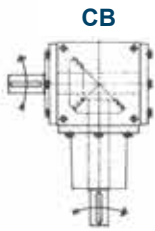

CB

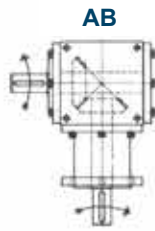

AB

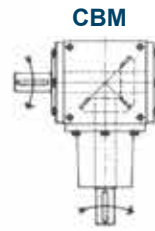

CBM

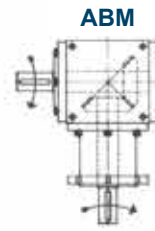

ABM

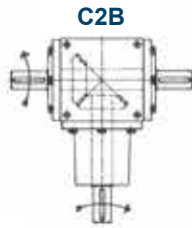

C2B

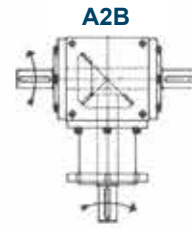

A2B

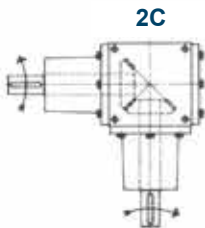

2C

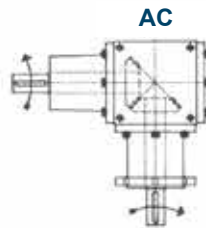

AC

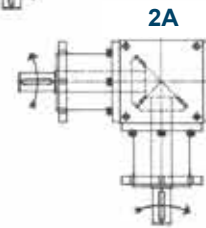

2A

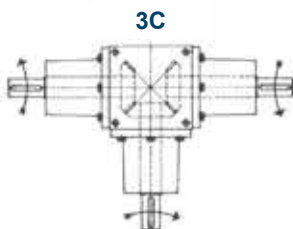

3C

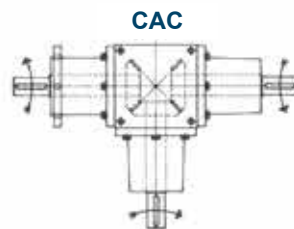

CAC

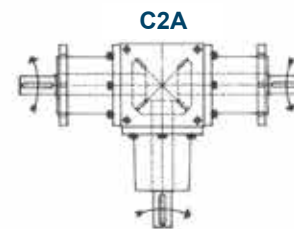

C2A

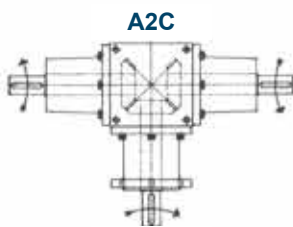

A2C

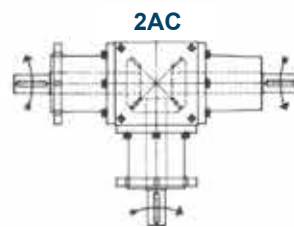

2AC

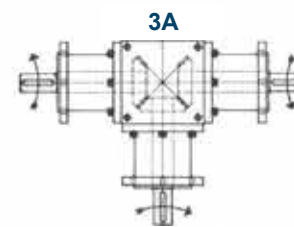

3A

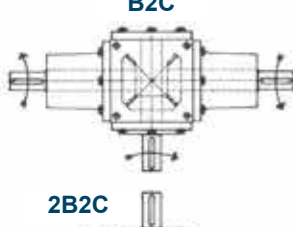

B2C

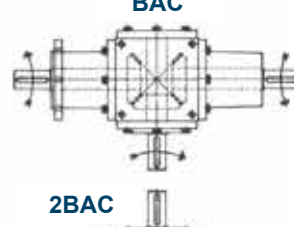

BAC

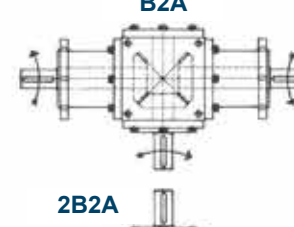

B2A

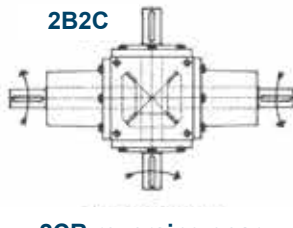

2B2C

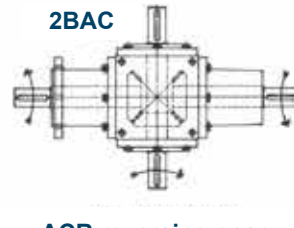

2BAC

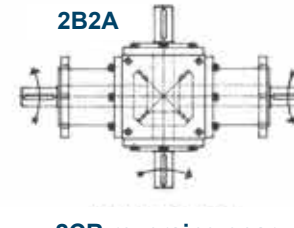

2B2A

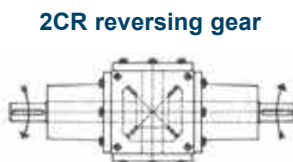

2CR reversing gear



ACR reversing gear

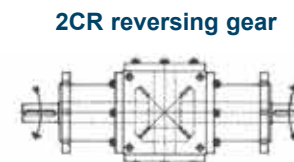

2CR reversing gear

## Type K - list of models

$i = 2:1$

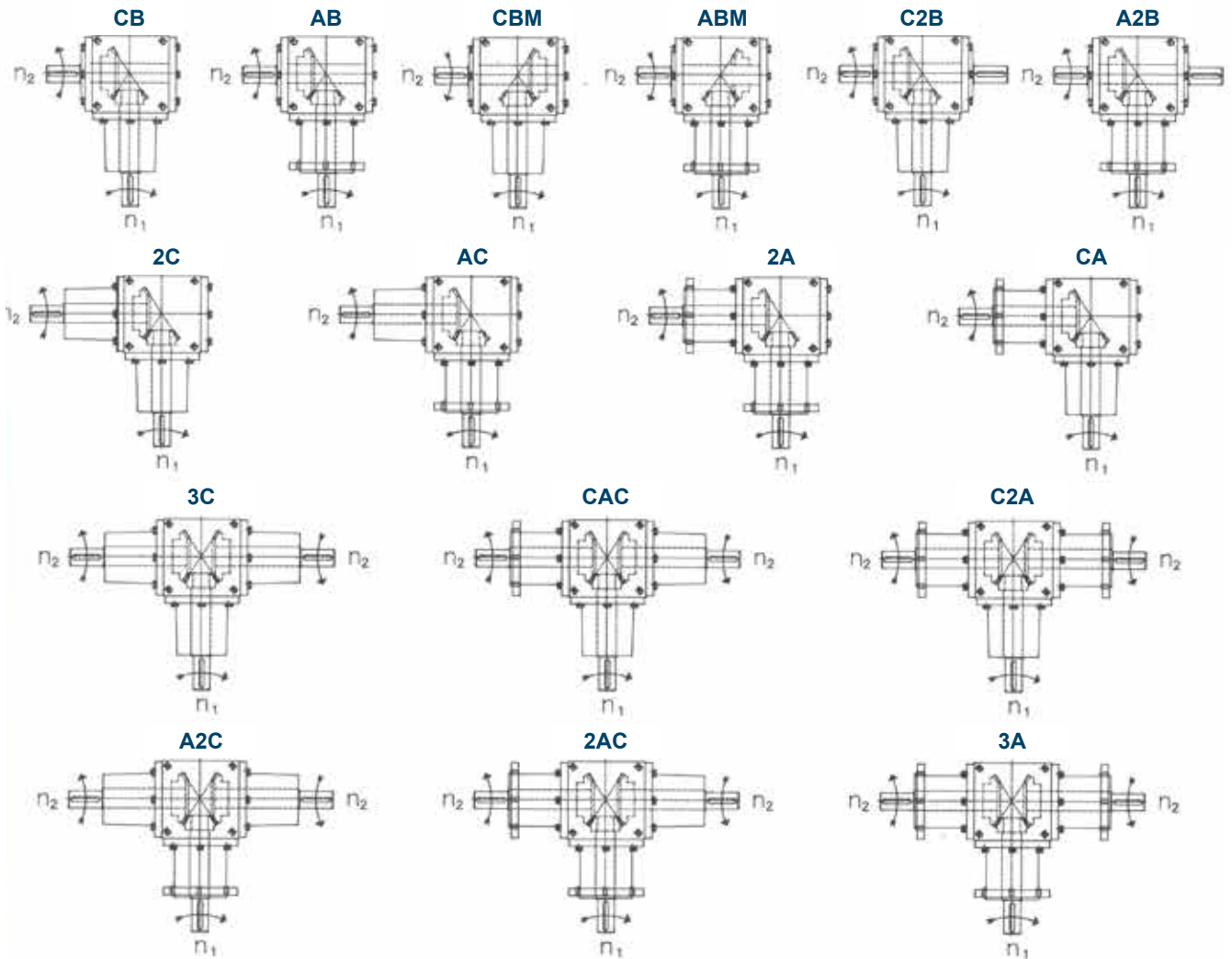

## Type K - list of models

$i = 1:2$

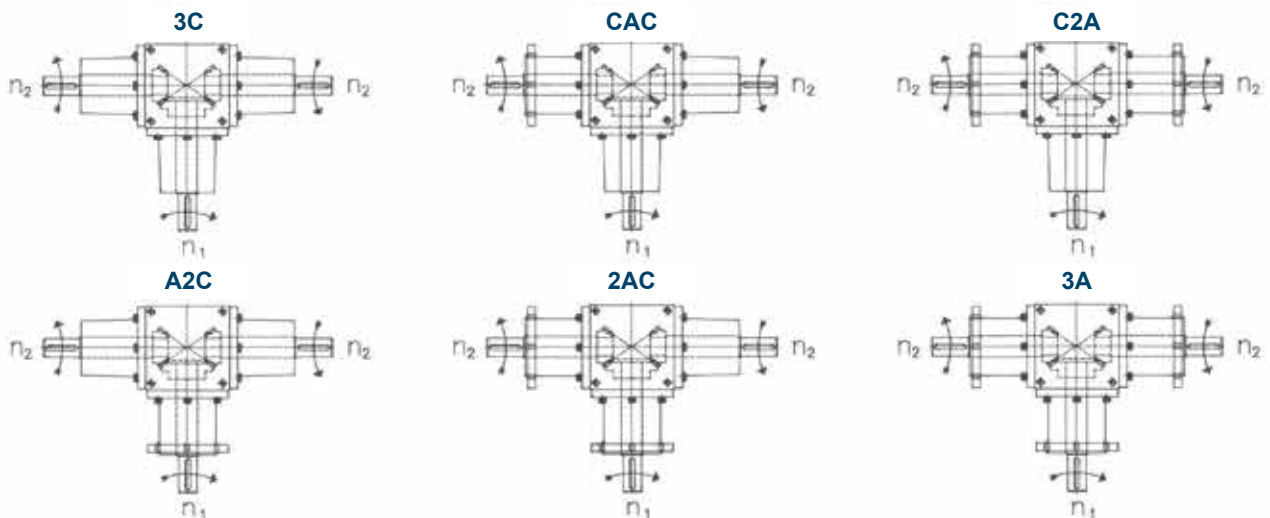

## Type K - list of models (continued)

$i = 1:2$

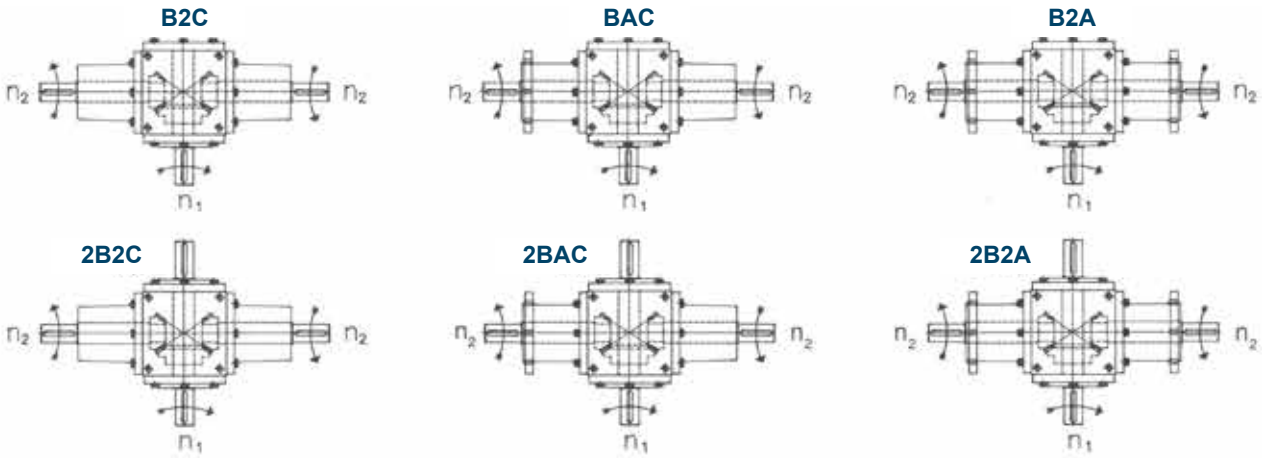

## Type K - examples of gearboxes

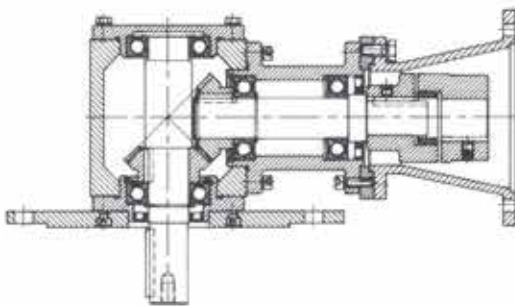

### **K25AB, $i = 1:1$**

Agitator gearbox, low overall height.  
Prepared for IEC motor.  
For DIN flange house at output.

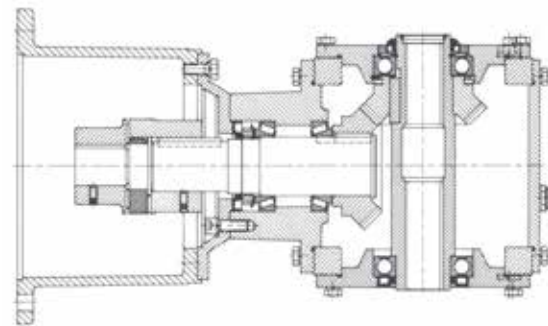

### **L50BC, $i = 1:1$**

Stainless hollow shaft  $\text{Ø}38$ .  
Motor flange for 132-160-180 B5 motor.  
Special sealing at hollow shaft.

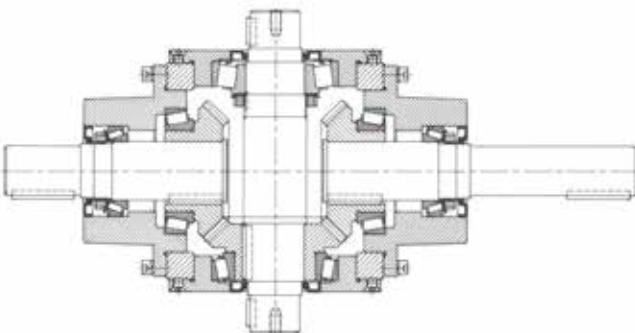

### **K502B2C, $i = 1:1$**

Adjusted for min. tooth play.  
For graphical machines.  
Special shafts at in- and output.

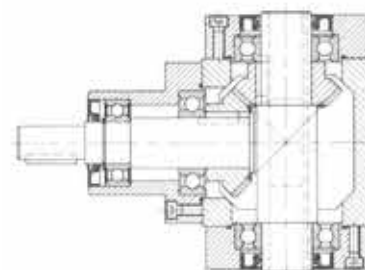

### **K20CH, $i = 1:1$**

Hollow shaft  $\text{Ø}20$ .  
Gear wheel as K25.

# Type K - dimensions

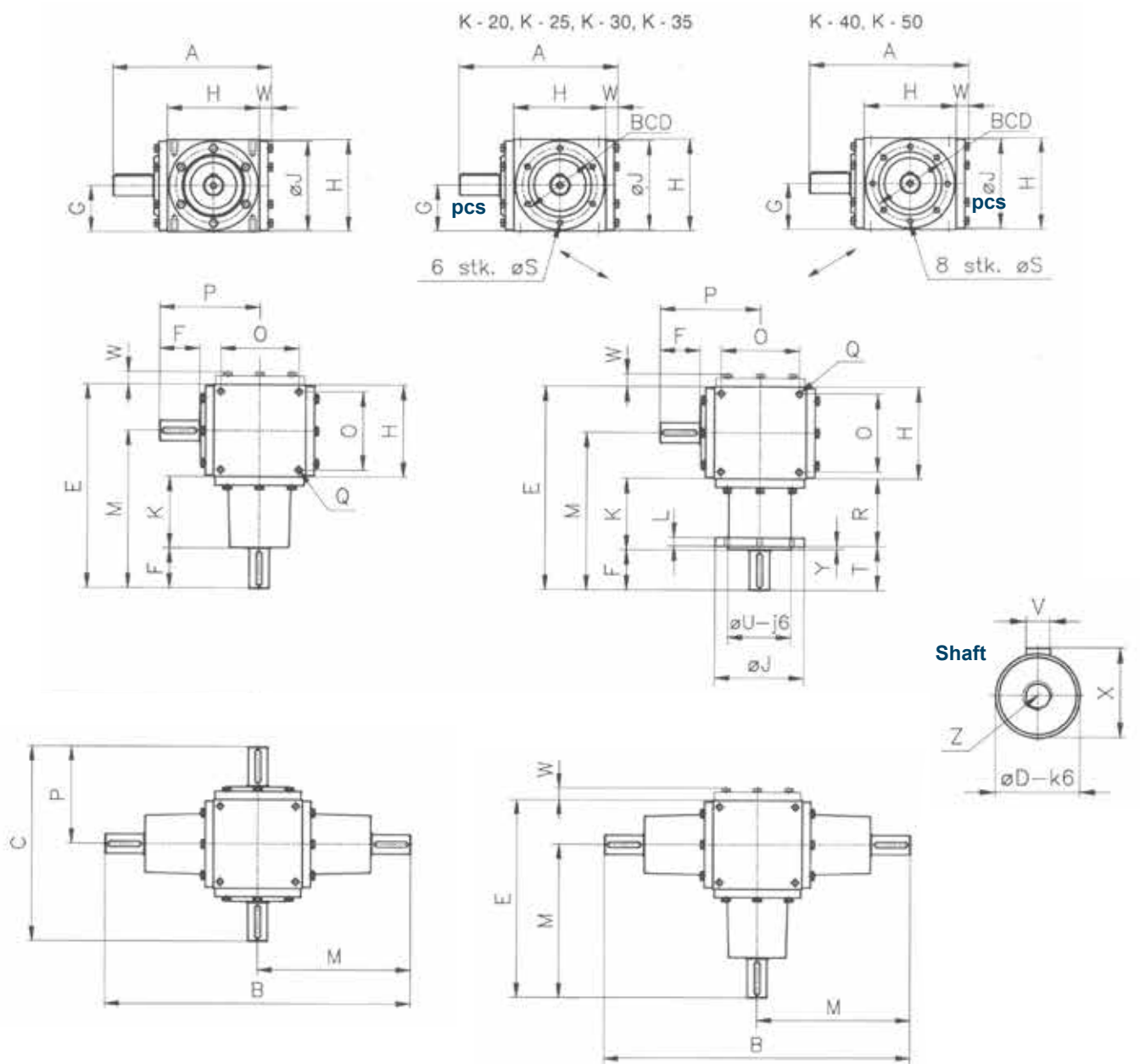

Gear	A	B	C	D	E	F	G	H	J	K	L	M	O	P	Q	R	S	T	U	V	W	X	Y	Z	BCD
K-20	180	334	228	20	217	45	50	100	92	72	10	167	80	114	M8X10	67	6	50	62	6	16	22,5	3	M8	80
K-25	213	414	276	25	265	60	58	116	112	89	11	207	96	138	M10X12	84	7	65	72	8	17	28	3	M10	96
K-30	252	474	320	30	307	65	70	140	136	102	15	237	115	160	M12X20	95	9	72	95	8	23	33	5	M12	115
K-35	227	550	350	35	355	70	80	160	155	125	15	275	136	175	M12x20	118	9	77	110	10	23	38	5	M12	130
K-40	332	610	416	40	405	80	100	200	195	125	15	305	170	208	M14x20	118	11	87	130	12	24	43	5	M12	165
K-50	390	680	488	50	460	95	120	240	235	125	17	340	210	244	M16x25	118	11	102	180	14	26	53,5	5	M16	215



## Type K - dimensions for mounting of motor

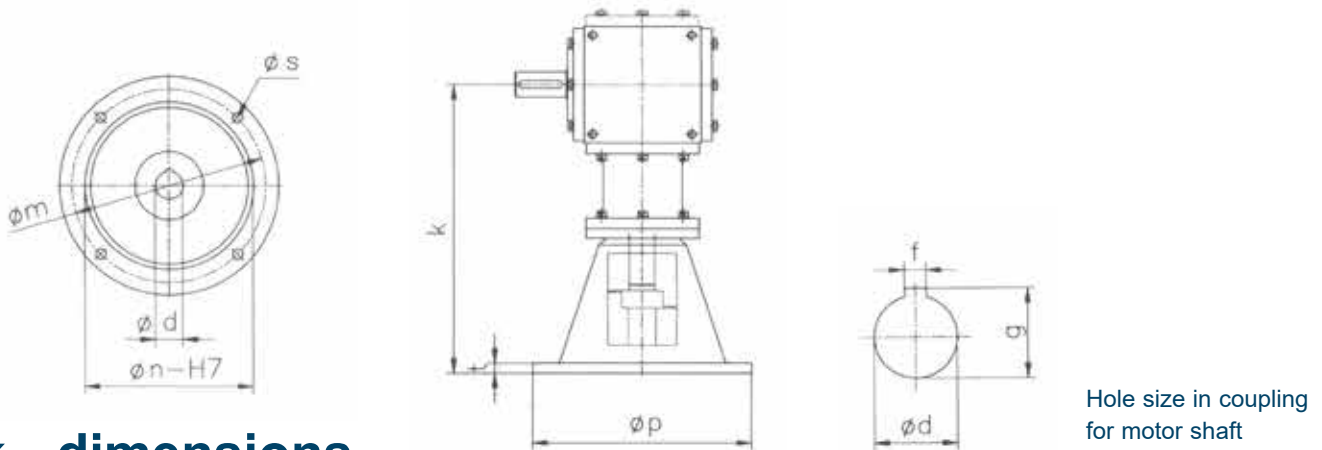

### k - dimensions

Motor Gear	71 B14	80 B14	90 B14	100 112 B14	132 B5	160 B5	180 B5
K-20	202	212	222	232			
K-25	227	237	247	247			
K-30		270	280	290			
K-35			306	316	396		
K-40					407	437	
K-50					418	448	448

Motor	d	f	g	m	n	p	s	t
71 B14	14	5	16,3	85	70	105	7	9
80 B14	19	6	21,8	100	80	120	7	9
90 B14	24	8	27,3	115	95	140	9	9
100/112 B14	28	8	31,3	130	110	160	9	9
132 B5	38	10	41,3	265	230	300	14	18*
160 B5	42	12	45,3	300	250	350	18	18
180 B5	48	14	51,8	300	250	350	18	18

Please contact our Sales Department for further information.

\* K-35, t=14 mm

## Type K - lubrication chart

Speed of the high speed shaft (rpm)			Gear size and lubricant number					
Over	-	Up to	20	25	30	35	40	50
2000	-	3000	3	3				
1500	-	2000	2	2	2	3		
1000	-	1500	1	1	1	1	1	1
500	-	1000	1	1	1	1	1	1
up to 500			1	1	1	1	1	1

All gear units are filled with EP mineral oil, type EP-150, and are completely closed. Therefore, they require very little attention. If the operating speed is over 1500 rpm, we must be informed when ordering, to fill with oil according to the lubrication chart.

Food grade oil is available.

Lubricant number	Specification ISO DP 6743/6 - AGMA 250.04 - DIN 51517/3	Viscosity by 40° C c St
	Factory filling	
1	EP 150	150
2	CLP 100	100
3	CLP 68	68

# Type K - spare parts

i = 1:1

- |    |                            |     |               |
|----|----------------------------|-----|---------------|
| 1  | Gearbox, 3-holes           | 13  | Oil seal      |
| 1A | Gearbox, 4-holes           | 14  | End cover     |
| 2  | Bearing casing C           | 15  | Circlip       |
| 2A | Bearing casing A           | 16  | Circlip       |
| 3  | Cover, open                | 16A | Distance ring |
| 4  | Cover, closed              | 17  | Key           |
| 5  | Wheel 1:1, left            | 18  | Key           |
| 6  | Wheel 1:1, right           | 19  | Key           |
| 7  | C-shaft                    | 20  | O-ring        |
| 8  | B-shaft                    | 20A | Paper gasket  |
| 8A | B-shaft, reversing gear    | 21  | Allen screw   |
| 9  | 2 B-shaft                  | 22  | Screw         |
| 9A | B-shaft, opposite rotation | 23  | Spring washer |
| 10 | Ball bearing               |     |               |
| 11 | Ball bearing 2 RS          |     |               |
| 12 | Oil seal                   |     |               |

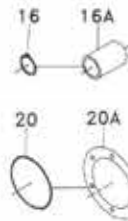

Until 95: Use 16A instead of 16

Until 95: Use 20A instead of 20

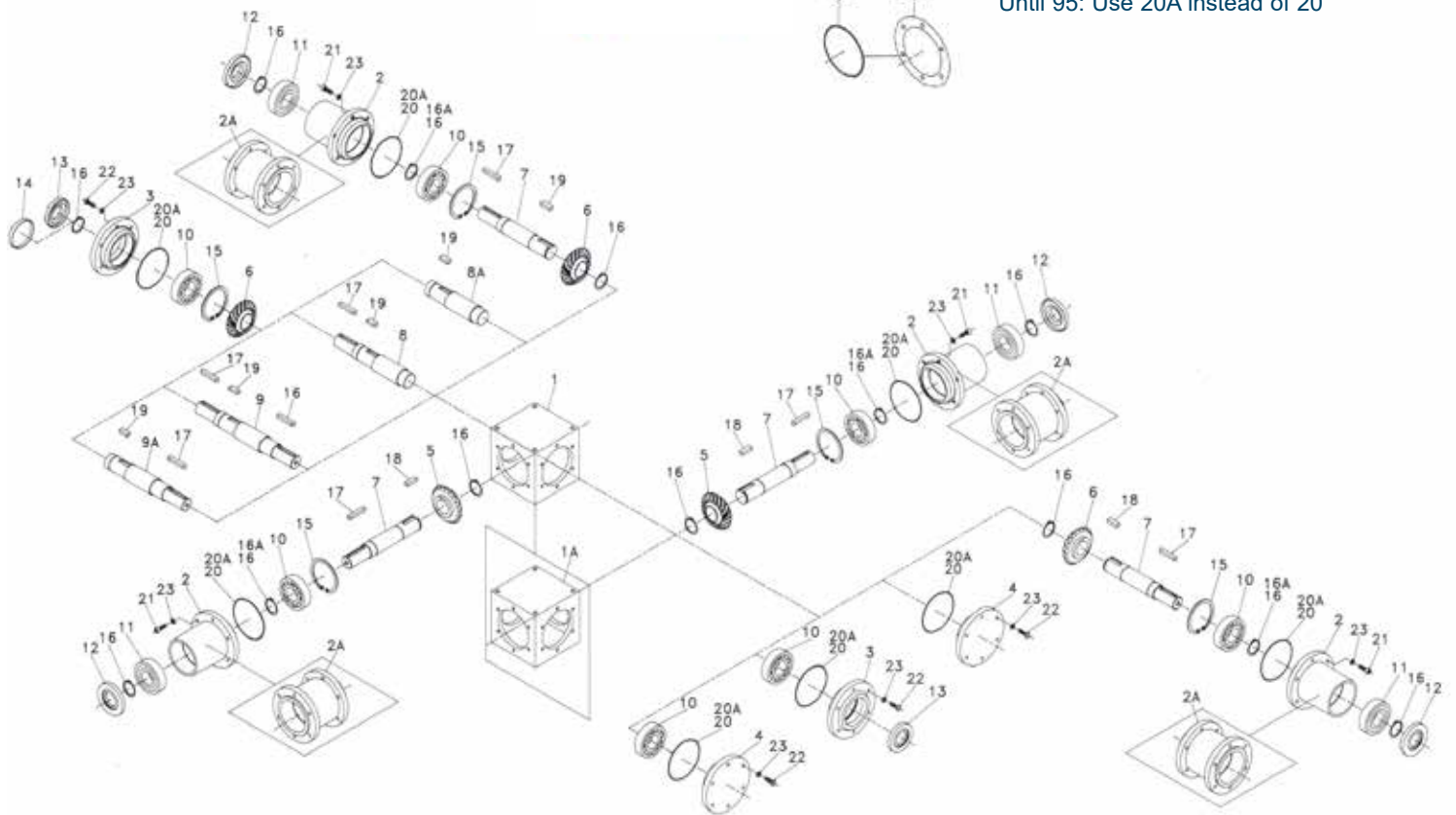

# Type K - spare parts

$i = 2:1$  and  $1:2$

1	Gearbox, 3-holes	14	End cover
1A	Gearbox, 4-holes	15	Circlip
2	Bearing casing C	16	Circlip
2A	Bearing casing A	16A	Distance ring
3	Cover, open	17	Key
4	Cover, closed	18	Key
5	Wheel shaft 2:1 + 1:2	19	Key
6	Wheel 2:1 + 1:2	20	O-ring
7	C-shaft	20A	Paper gasket
8	B-shaft	21	Allen screw
9	2 B-shaft	22	Screw
9A	B-shaft, opposite rotation	23	Spring washer
10	Ball bearing		
11	Ball bearing 2 RS		
12	Oil seal		
13	Oil seal		

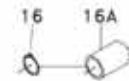

Until 95: Use 16A instead of 16

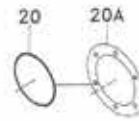

Until 95: Use 20A instead of 20

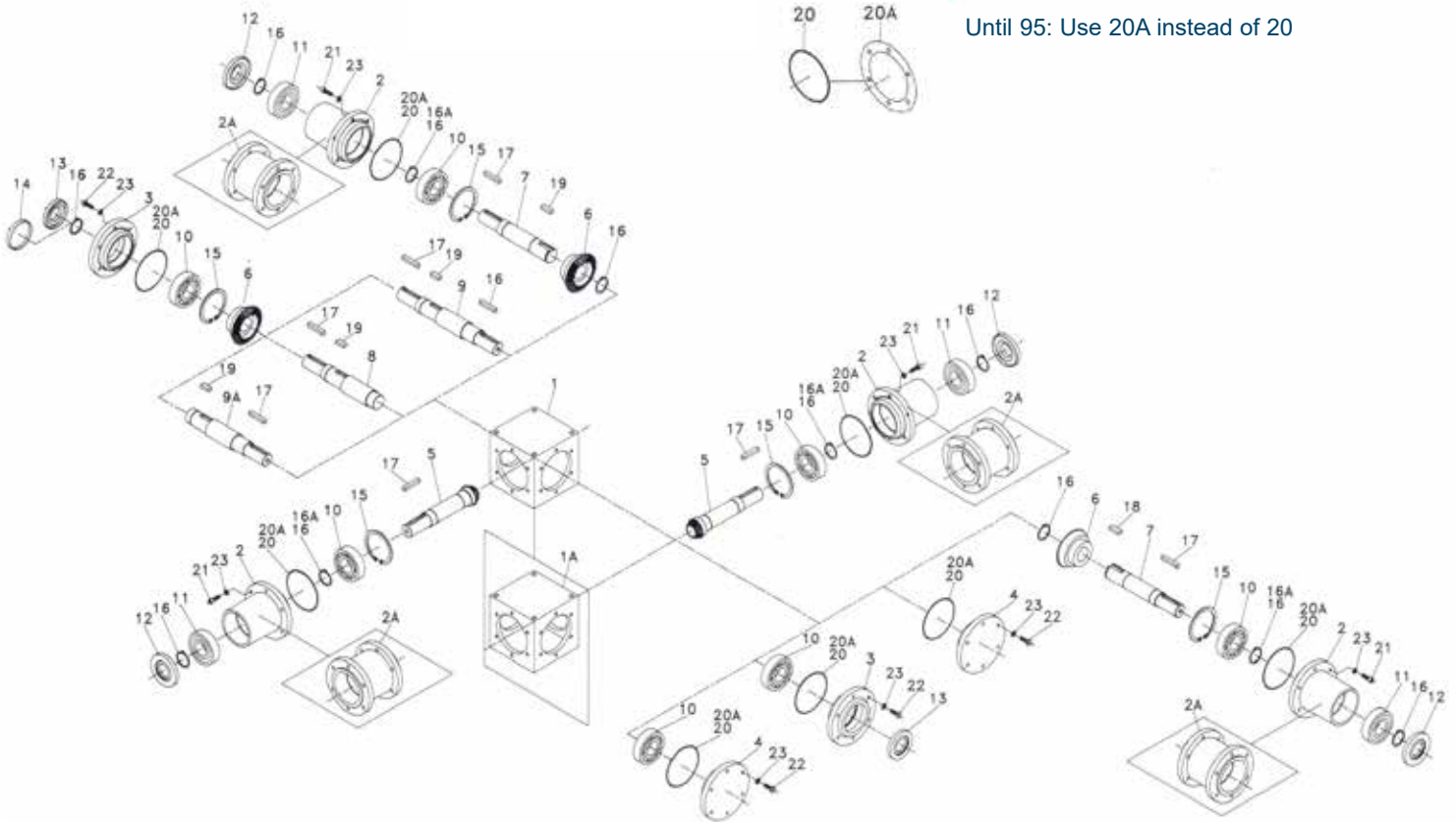

## Type P and V



## Type P and V - efficiency data

Permissible power  $P_1$  [kW] and rated output torque  $M_2$  [Nm]

Ratio	Input rpm.	Gear sizes				Ratio	Input rpm	Gear sizes			
		25		30				25		30	
		$P_1$	$M_2$	$P_1$	$M_2$			$P_1$	$M_2$	$P_1$	$M_2$
		kW	Nm	kW	Nm			kW	Nm	kW	Nm
1:1	10	0,29	270	0,6	550	1:1	200	5,5	250	11,5	525
	25	0,74	270	1,5	550		300	8,2	250	16,8	510
	50	1,48	270	3,0	550		400	10,8	245	22	500
	75	2,15	260	4,4	540		500	13,2	240	26,7	485
	100	2,85	260	6,0	540		600	15,5	235	31,4	475
	150	4,2	255	8,8	535						

## Type P and V - service factors

Type P & V	Service factors								
	Starters per hour								
	≤ 10			11-150			>150		
Working conditions	Intermittent operation up to 3 hours a day	Normal operation 8-10 hours a day	24 hours operation a day	Intermittent operation up to 3 hours a day	Normal operation 8-10 hours a day	24 hours operation a day	Intermittent operation up to 3 hours a day	Normal operation 8-10 hours a day	24 hours operation a day
1. Smooth, shock free loading and low starting torque	0,8	1,0	1,25	1,0	1,25	1,5	1,25	1,5	1,75
2. Moderate shock loads and medium starting torque.	1,0	1,25	1,5	1,25	1,5	1,75	1,5	1,75	2,0
3. Smooth loading with periodically heavy shock loads and high starting torque	1,25	1,5	1,75	1,5	1,75	2,0	1,75	2,0	2,25
4. Heavy continuous shock loads and very high starting torque	1,5	1,75	2,0	1,75	2,0	2,25	2,0	2,25	2,5

P & V gearboxes are filled with Rando HD 100 oil

# Type P and V - list of models

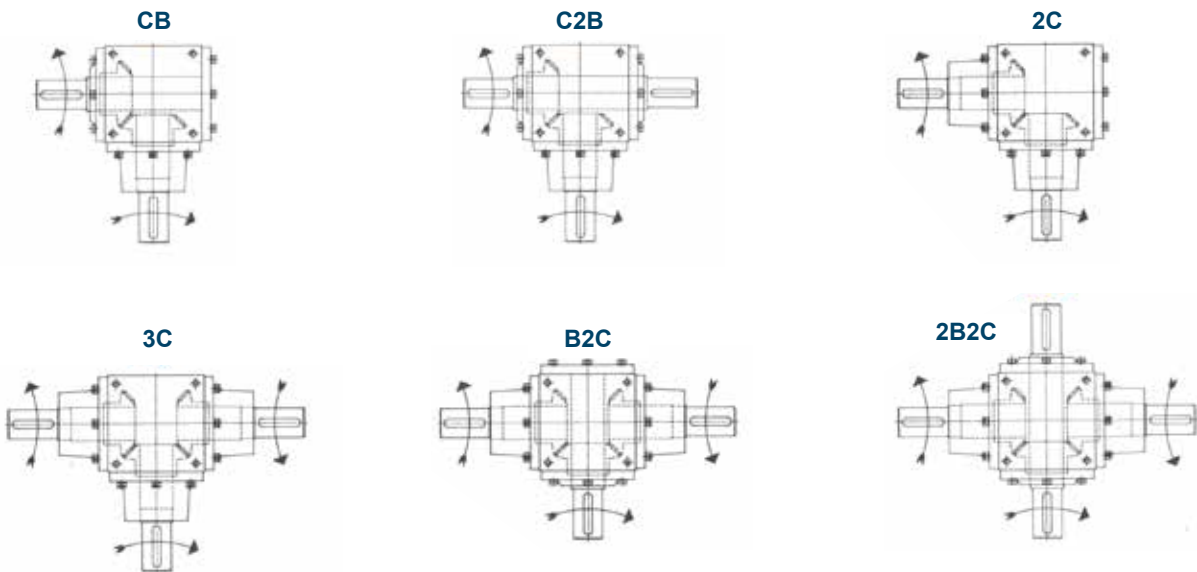

# Type V - dimensions

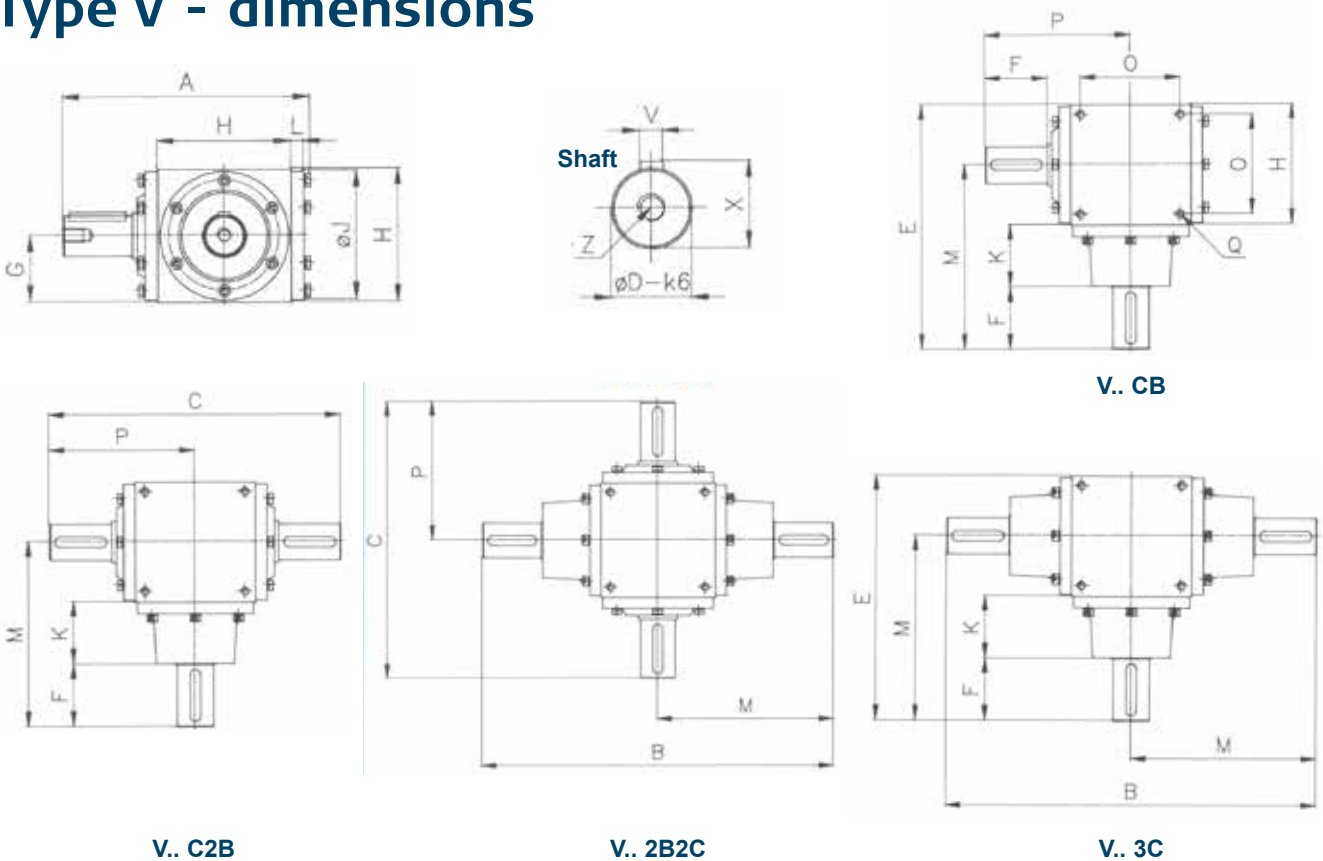

Gear	A	B	C	D	E	F	G	H	J	K	L	M	O	P	Q	V	X	Z
V-25	215	360	280	35	238	60	58	116	112	62	11	180	96	140	M10X15	10	38	M12
V-30	263	430	340	40	285	70	70	140	136	75	15	215	115	170	M12X20	12	43	M12

# Type P - dimensions

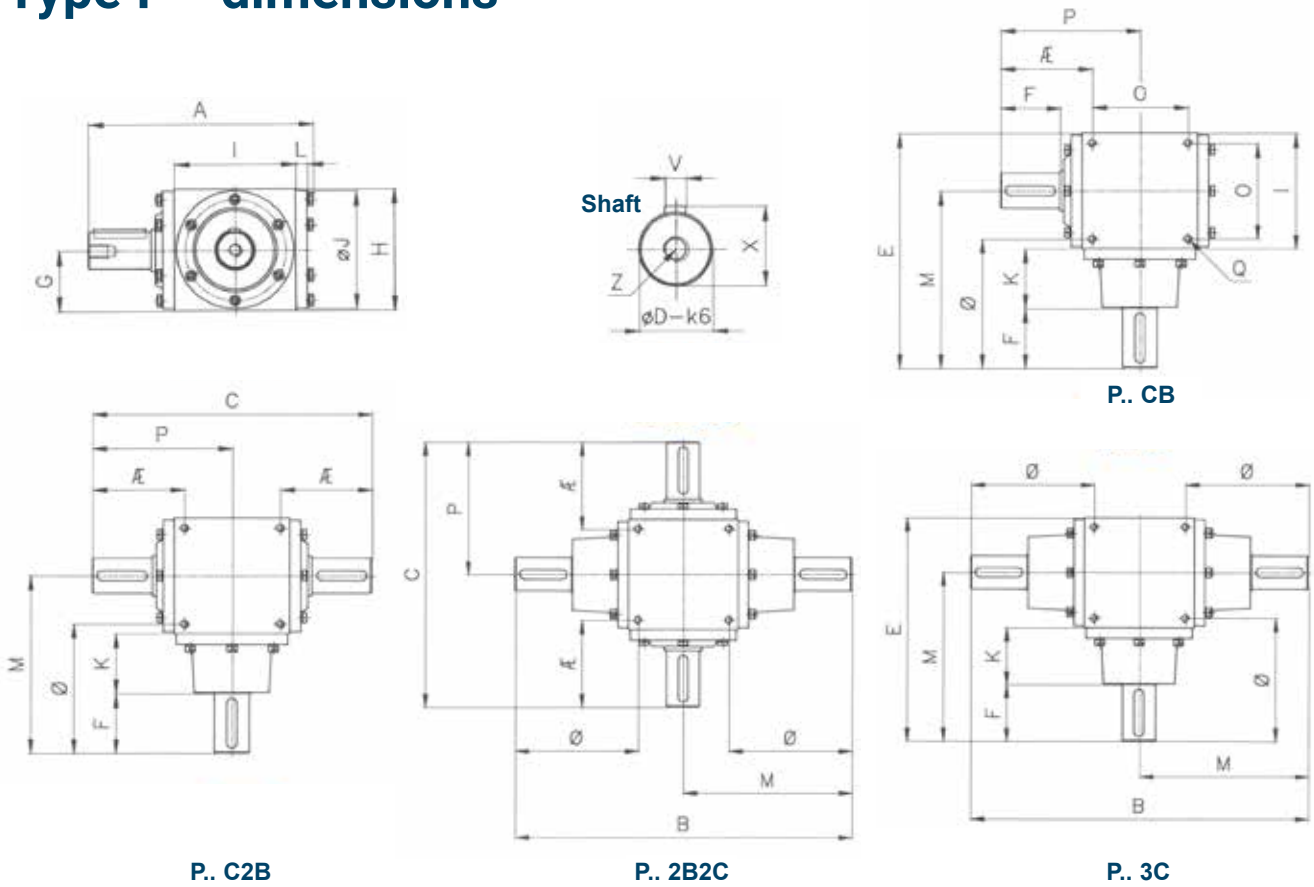

Gear	A	B	C	D	E	F	G	H	I	J	K	L	M	O	P	Q	V	X	Z	ε	Ø
P-25	215	360	280	35	238	60	55	110	116	108	62	11	180	88	140	M8X10	10	38	M12	96	136
P-30	263	430	340	40	285	70	70	140	140	136	75	15	215	110	170	M10X15	12	43	M12	115	160



# Type P and V - spare parts

i = 1:1

1	Gearbox, 3-holes	12	Tapered roller bearing
1A	Gearbox, 4-holes	13	Oil seal
2	Bearing casing C	14	Oil seal
3	Cover, open	15	Adjusting nut
4	Cover, closed	16	Lock washer
5	Wheel 1:1, left	17	O-ring
6	Wheel 1:1, right	18	Key
7	C-shaft	19	Screw
8	B-shaft	20	Allen screw
9	2 B-shaft	21	Spring washer
10	Tapered roller bearing		
11	Tapered roller bearing		

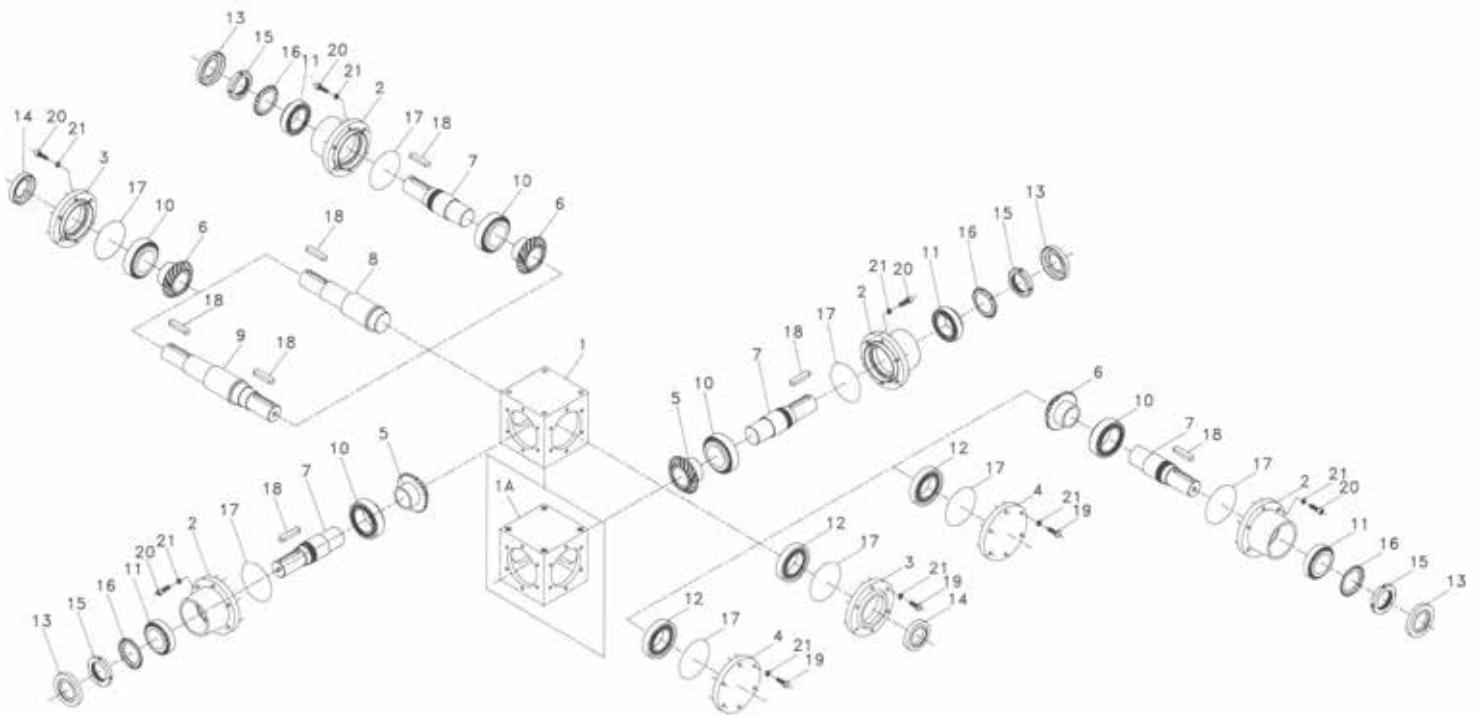

# bj·gear

Customisation is our standard



## BJ-Gear A/S

Niels Bohrs Vej 47  
DK-8660 Skanderborg, Denmark  
VAT No. DK 10166470

Phone +45 87 40 80 80  
Email [bj@bj-gear.com](mailto:bj@bj-gear.com)  
Website [www.bj-gear.com](http://www.bj-gear.com)

Copyright © 2023 BJ-Gear A/S. All product rights reserved. All data, illustrations, photos, drawings and statements are for general information only and subject to change without notice and should not be considered as a warranty or legal obligation of any kind.